

Les sources d'inspirations
sont multiples et parfois
tout simplement techniques.

La chaise Iso
est issue d'une série
de contraintes ou plutôt
d'un challenge.

Il en résulte une chaise
au dessin structurel
apportant toute la résistance
nécessaire avec
des épaisseurs
matière minimum.

Iso

by Cédric Ragot

The inspirations are varied and sometimes quite technical. Iso is the chair after a series of constraints or rather a challenge. The result is a chair in structural design providing all the necessary strength with minimum material thickness.

Inspiration



ISO by Cédric Ragot

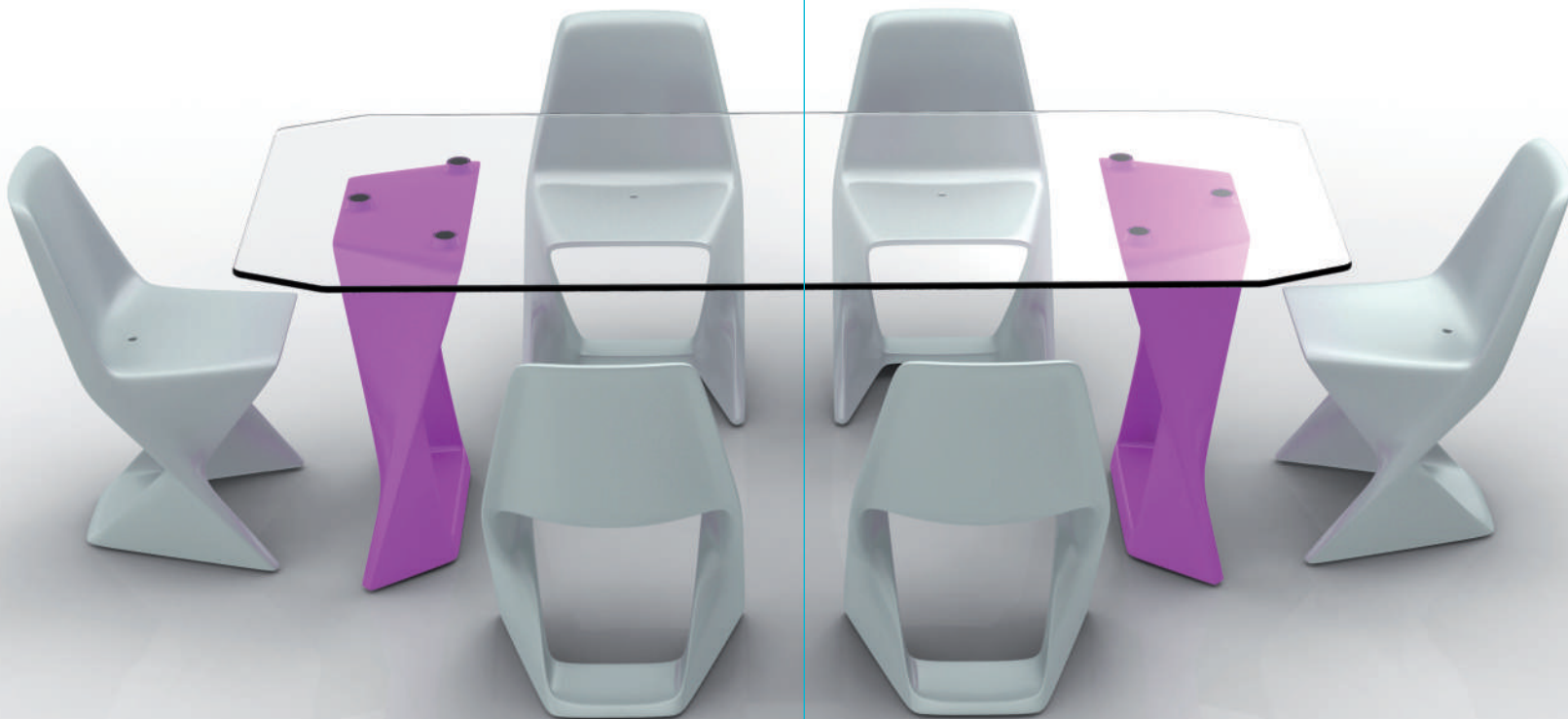

Caractéristiques

Utilisé dans toute la collection

- Fabriqué en France
- Polyéthylène HD
- Résistance aux UV
- Teinté dans la masse
- Entièrement recyclable
- Emballage carton individuel
- Supporte des températures de -30°C à +50°C

Entretien

Nettoyer au moyen d'un chiffon doux avec un mélange d'eau chaude et de détergeant non agressif.
Ne pas utiliser d'eau de javel, de dépolissant ou de nettoyant agressif.

Characteristics

Used in all the collection

- Made in France
- HD Polyethylene
- UV resistance
- Tinted in the mass
- Recyclable
- Individual carton packaging
- Resists to temperatures from -30°C to +50°C

Cleaning instructions

Keep clean with soft cloth and a solution of warm water and a non aggressive detergent.
Do not use bleach, stain remover or aggressive cleaning agents.

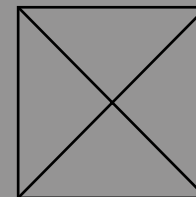

Nuancier Qui est Paul ? TM / Colour chart Qui est Paul ? TM

Tout le mobilier illustré dans ce catalogue existe dans ces 17 coloris
All furniture illustrated in this catalogue exist in these 17 colors

[01]	[02]	[03]	[04]	[05]	[06]	[07]	[08]	[09]	[10]	[11]	[12]	[13]	[14]	[15]	[16]	[17]
Noir Black RAL 9005	Chocolat Chocolate RAL 8017	Gris Grey Pantone 423 C	Kaki Khaki RAL 6013	Beige Beige Pantone 7500 C	Fushia Fushia Pantone 4010	Jaune Yellow RAL 1016	Vert Green Pantone 382 C	Orange Orange RAL 2004	Rouge Red Pantone 485 C	Violet Purple RAL 4008	Turquoise Turquoise RAL 6027	Blanc White RAL 9010	Gris Anthracite Dark Grey Pantone 425 C	Bleu Nuit Night Blue RAL 5008	Bleu Blue Pantone 5405 C	Bordeaux Burgundy RAL 3005

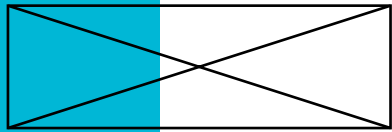

Plateau Verre Sécurité
ou HPL 2 coloris au choix (blanc/noir)

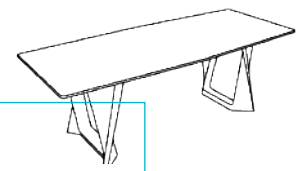
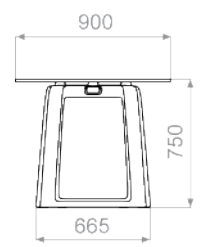
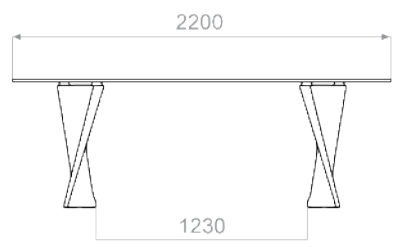
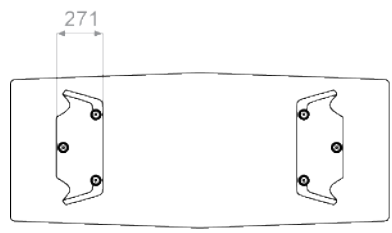
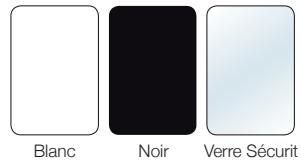

Table

Table ultra fine à la ligne pure et affirmée. La table ISO associe un piètement style tréteaux avec 17 coloris au choix dans 2 versions de plateaux HPL blanc ou noir (1) 24 mm et verre sécurité (2) 15 mm. La table ISO forme un ensemble parfait avec les chaises Iso, tout en harmonie de couleurs et de formes.

- (1) Poids : 30 Kg
- (2) Poids : 90 Kg

Table ultra thin presents line pure and affirmed. It combines style with trestle base in 17 colors in 2 versions of plates HPL white or black (1) 24 mm and secure glass (2) 15 mm. The Iso table forms a perfect set with chairs Iso, while harmony of colors and shapes.

- (1) Weight: 30 Kg
- (2) Weight: 90 Kg

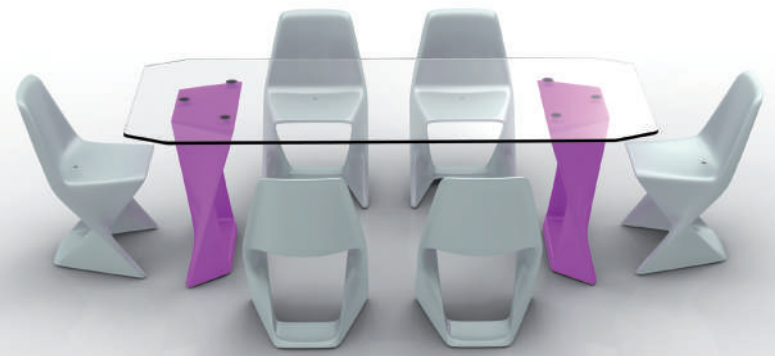

ISO by Cédric Ragot

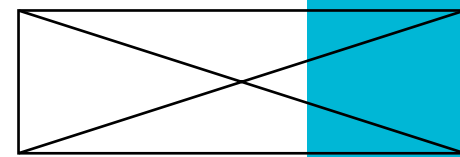
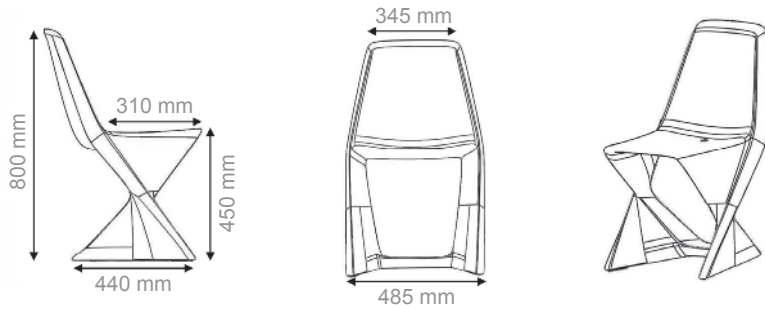

**Empilable
Stacking**

Chaise

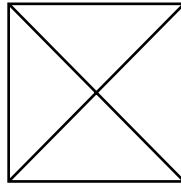

Les sources d'inspirations sont multiples et parfois tout simplement techniques. La chaise Iso est issue d'une série de contraintes ou plutôt d'un challenge. Celui de réaliser en rotomoulage une chaise empilable, confortable, tout en économisant au maximum la matière. Il en résulte une chaise au dessin structurel apportant toute la résistance nécessaire avec des épaisseurs matière minimum.

The inspirations are varied and sometimes quite technical. Iso is the chair after a series of constraints or rather a challenge. That of establishing a stackable chair in rotational molding, comfortable, and save up the matter. The result is a chair in structural design providing all the necessary strength with minimum material thickness.

Weight: 7.5 Kg

Poids : 7.5 Kg



www.qui-est-paul.com

ISO by Cédric Ragot

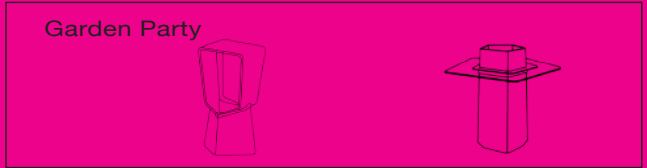
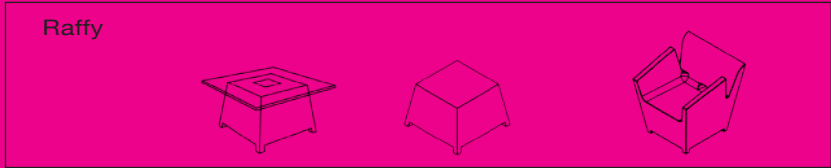
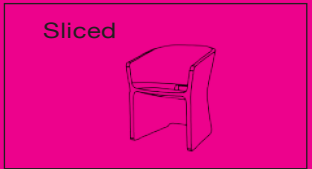
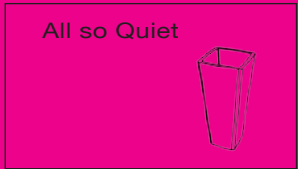
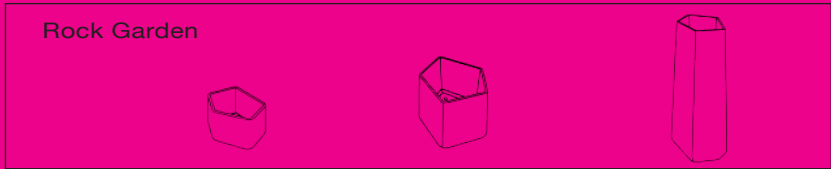
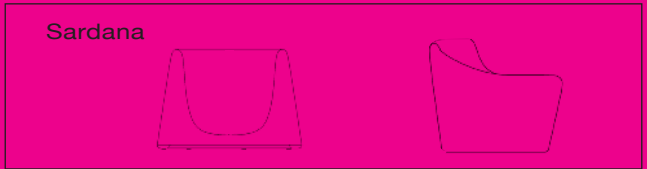
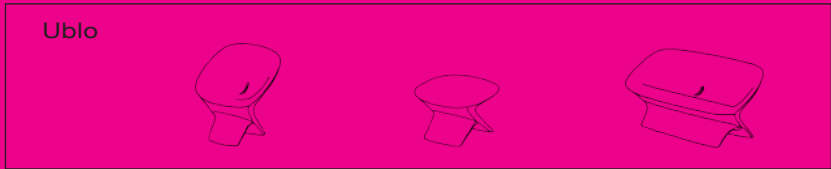
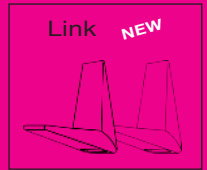
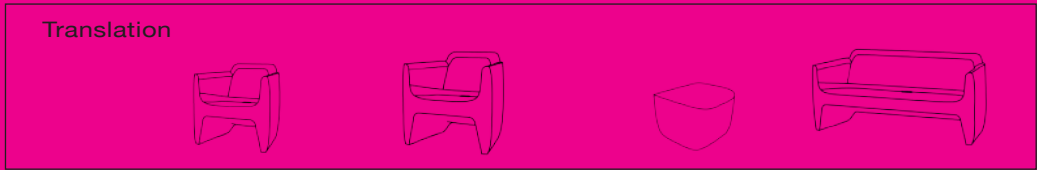
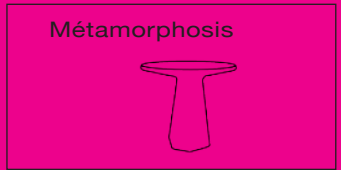
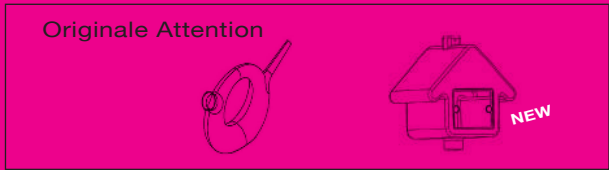
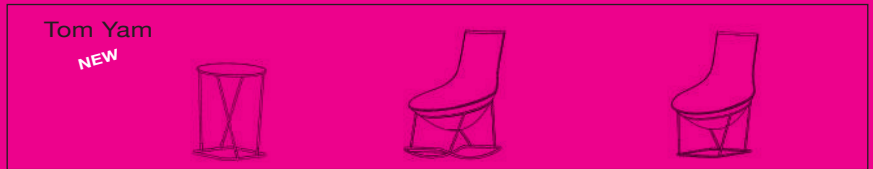
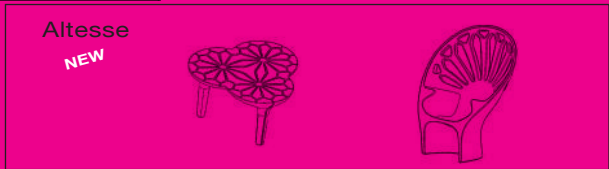
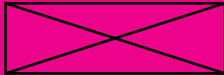

The French Touch

The French Touch

www.qui-est-paul.com