

Un grand classique revisité
tout en finesse et traité
de manière sculpturale.

Des lignes précises et fluides qui
sont comme coupées au scalpel.

Un jeu sur la lumière, le galbe, et
une transition formelle
qui donnent un mouvement
à la ligne de la chaise.

Sliced

by Alain Gilles

A great classic revisited in a sculptural way with a careful attention paid to every details. Fluid and sharp construction lines that have been cut with the precision of a scalpel. Careful play with light, curvature lines and a formal transition between top and bottom that gives the chair its distinctive movement.



pureté des lignes
lignes d'évasion

Caractéristiques

Utilisé dans toute la collection

- Fabriqué en France
- Polyéthylène HD
- Résistance aux UV
- Teinté dans la masse
- Entièrement recyclable
- Emballage carton individuel
- Supporte des températures de -30°C à +50°C

Entretien

Nettoyer au moyen d'un chiffon doux avec un mélange d'eau chaude et de détergeant non agressif.
Ne pas utiliser d'eau de javel, de dépolissant ou de nettoyant agressif.

Characteristics

Used in all the collection

- Made in France
- HD Polyethylene
- UV resistance
- Tinted in the mass
- Recyclable
- Individual carton packaging
- Resists to temperatures from -30°C to +50°C

Cleaning instructions

Keep clean with soft cloth and a solution of warm water and a non aggressive detergent.
Do not use bleach, stain remover or aggressive cleaning agents.

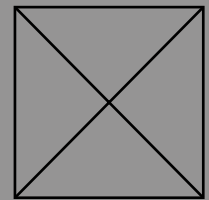

Nuancier Qui est Paul ? TM / Colour chart Qui est Paul ? TM

Tout le mobilier illustré dans ce catalogue existe dans ces 17 coloris
All furniture illustrated in this catalogue exist in these 17 colors

[01]	[02]	[03]	[04]	[05]	[06]	[07]	[08]	[09]	[10]	[11]	[12]	[13]	[14]	[15]	[16]	[17]
Noir Black RAL 9005	Chocolat Chocolate RAL 8017	Gris Grey Pantone 423 C	Kaki Khaki RAL 6013	Beige Beige Pantone 7500 C	Fushia Fushia Pantone 4010	Jaune Yellow RAL 1016	Vert Green Pantone 382 C	Orange Orange RAL 2004	Rouge Red Pantone 485 C	Violet Purple RAL 4008	Turquoise Turquoise RAL 6027	Blanc White RAL 9010	Gris Anthracite Dark Grey Pantone 425 C	Bleu Nuit Night Blue RAL 5008	Bleu Blue Pantone 5405 C	Bordeaux Burgundy RAL 3005

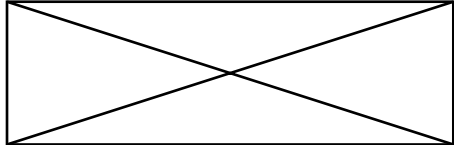

Plateau en mélaminé Haute Densité
4 coloris au choix

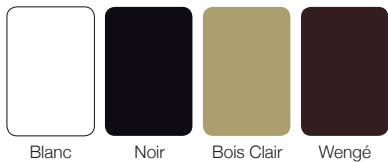

Blanc

Noir

Bois Clair

Wengé

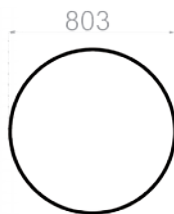

803



30

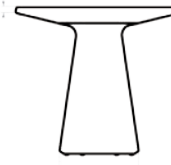

382

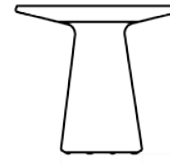

720

391

Table ronde



Un jeu sur la personnalité multiple d'un objet unique. Sur des caractères différents en fonction du regard et de l'angle de vue.
Un objet aux multiples facettes. Pour qu'une seule pièce une fois répétée puisse donner naissance à un foisonnement d'impressions confuses, incertaines et intrigantes.
Un travail sur la notion de poids visuel de l'objet, d'équilibre et de stabilité. Pour qu'une petite table, pratique et fonctionnelle, puisse générer une tension et un questionnement.
Un objet permettant de créer des installations non statiques, en perpétuel changement.

Poids : 15 Kg

A play on the multiple personalities of an unique object. Characteristics which change with every look and every angle. An object with multiple facets. One single piece provokes an abundance of intriguing and changing impressions. A work based on visual impact, equilibrium and stability. This small, practical and functional table creates questions and tension, although static it gives an impression of movement and perpetual change.

Weight: 15 Kg



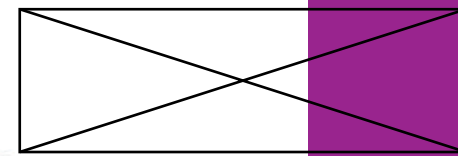
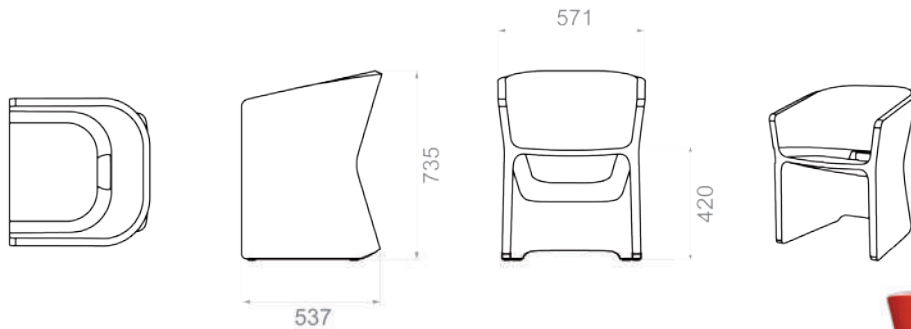

Sliced chair

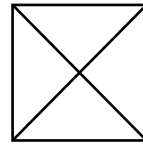

Un grand classique revisité tout en finesse et traité de manière sculpturale. Des lignes précises et fluides qui sont comme coupées au scalpel. Un jeu sur la lumière, le galbe, et une transition formelle qui donnent un mouvement à la ligne de la chaise. Un siège englobant et confortable conçu pour s'adapter à des usages très variés et se libérer de certaines contraintes habituellement liées à la technologie mise en œuvre. Passer allègrement de l'intérieur à l'extérieur en fonction des saisons et des envies.

Poids : 10 Kg

A great classic revisited in a sculptural way with a careful attention paid to every details. Fluid and sharp construction lines that have been cut with the precision of a scalpel. A careful play with light, curvatuture lines and a formal transition between top and bottom that gives the chair its distinctive movement. A chair that is both welcoming, comfortable, and designed to adapt itself to a wide variety of uses. Technically, this piece has also freed itself from most of the constraints usually associated with the technology put in use for its production. Depending on your mood and weather, this chair will feel perfectly at home indoor or outdoor, used as a stand alone piece or around a diner or conference table.

Weight: 10 Kg

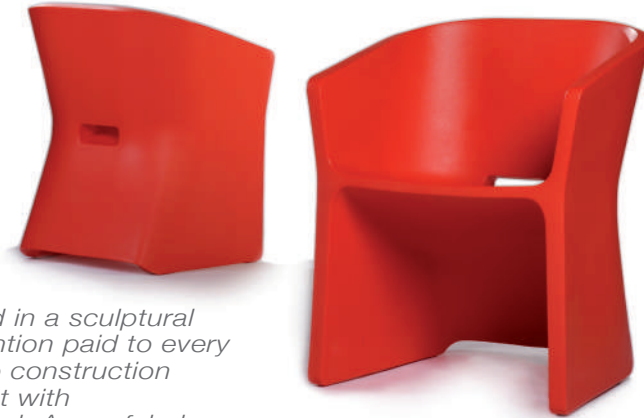

Sliced by Alain Gilles

www.qui-est-paul.com

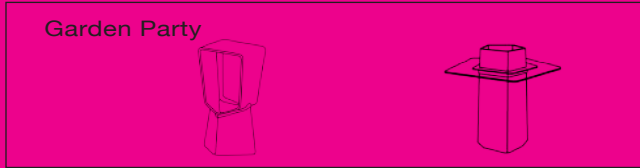
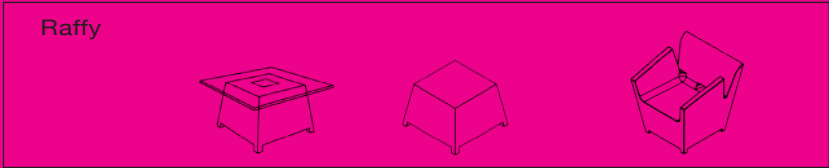
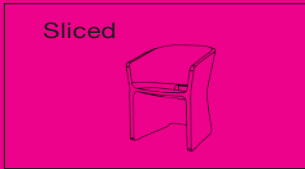
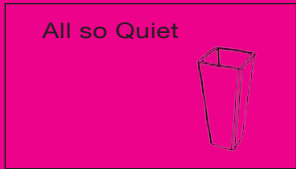
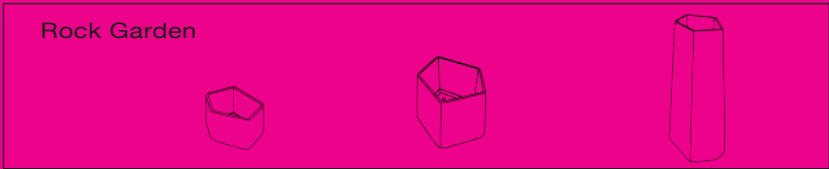
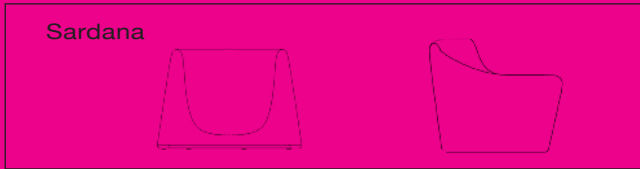
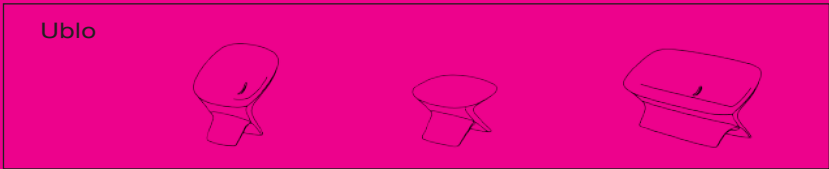
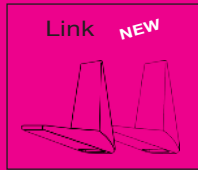
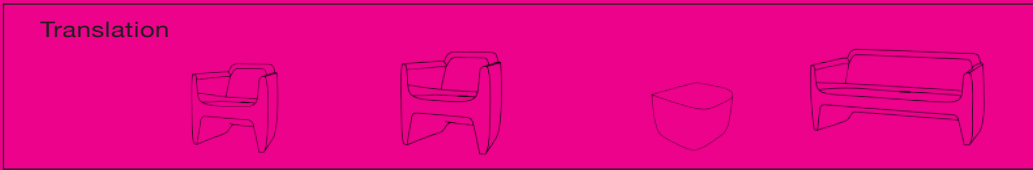
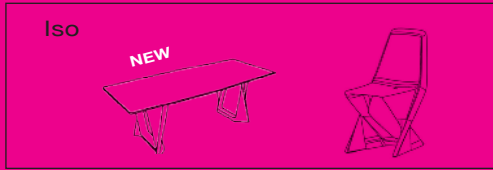
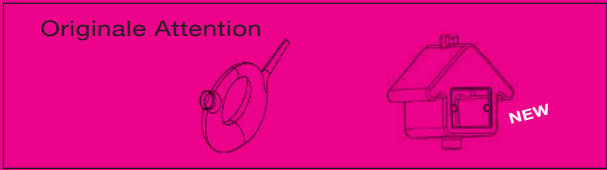
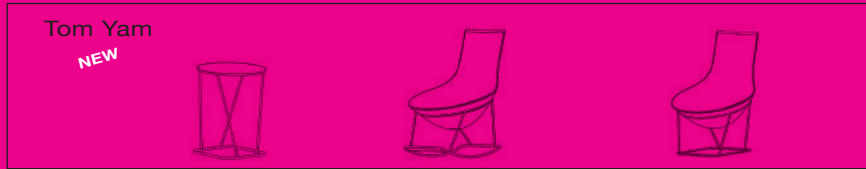
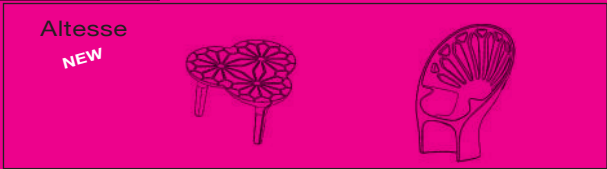
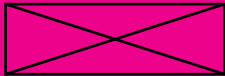

The French Touch

The French Touch

www.qui-est-paul.com